

**Combination type – CLASS I+II+III (Clearap)  
(CV067515)**

**B25VT-385V-FS-3P**

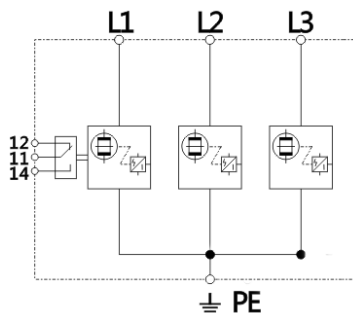

Outside drawing



Basic circuit diagram

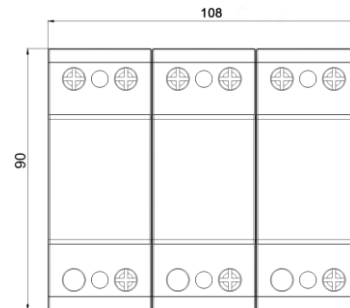

Dimension drawing

Type 1+2+3 surge arrester designed for low-voltage power supply system protection against surges at the boundaries from lightning protection zone 0<sub>B</sub> -3 and higher.

- Class I+II+III/B+C+D SPD in accordance with IEC61643-11 and UL1449-4<sup>th</sup>
- High surge capacity of 25kA 10/350 per pole and I<sub>max</sub> 120kA 8/20
- Reliable supervision due to disconnection device
- With remote alarm terminal optional

| Part No.  | B25VT-385V-FS/3P   |
|---|--|
| In accordance with  | IEC61643-11:2011; UL1449-4th                                     |
| Category IEC/VDE  | I+ II +III/ B+C+D  |
| Max. continuous operating voltage U <sub>c</sub>            | 385VAC   |
| Nominal discharge current(8/20) I <sub>n</sub>              | 25kA   |
| Max. discharge current(8/20) I <sub>max</sub>               | 120kA  |
| Lightning impulse current(10/350) I <sub>imp</sub>          | 25kA   |
| Voltage protection level @I <sub>n</sub>                    | <1,5kV   |
| Response time   | ≤100 ns  |
| Follow current  | No   |
| Backup fuse(only required if not already provided in mains) | 250A gL/gG   |
| Operating temperature range                                 | - 40°C ~ + 80°C  |
| Cross-section of connection wire                            | Single-strand 35mm <sup>2</sup> ; multi-strand 25mm <sup>2</sup> |
| Torque applied by the screws                                | 2.0-2.5 Nm   |
| Mounting  | 35mm DIN-rail in accordance with EN 50022/DIN46277-3             |
| Enclosure material  | thermoplastic; extinguishing degree UL94 V-0                     |
| Housing protection level                                    | IP20   |
| Installation width  | 6 modules, DIN 43880   |
| Thermal disconnecter  | Internal green – normal ; red - failure                          |
| Remote alarm contact  | Yes  |
| Additional data for Remote Alarm Contacts                   | Closed and open 1.5mm <sup>2</sup> / 0.5 Nm ,max                 |
| Remote alarm contact type                                   | Isolated Form C  |
| Switching capability Un/In                                  | AC: 250V/0.5A DC: 250V/0.1A; 125V/0.2A; 75V/0.5A                 |
| Max. Size of connecting wire                                | Max. 1.5mm <sup>2</sup> (or # 16AWG)                             |